

AN IMPROVED MATHEMATICAL MODELING AND SIMULATION OF EV

P.SARALA, BALASWETHA

Dept of EEE,

Priyadarshini Institute of Science and Technology for Women Khammam.

Abstract— For research, we have selected 5 papers if work presented we studied in detail and organizational in the form of research paper . Mathematical modeling and simulation of electric vehicles (EVs) are crucial for understanding and optimizing their performance, energy consumption, and various aspects of their operation. These models and simulations help engineers, researchers, and policymakers develop and assess EV technologies and infrastructure. Here is an overview of the key aspects of mathematical modeling and simulation for electric vehicle. These mathematical models and simulations contribute to the development and optimization of electric vehicles, making them more efficient, safer, and sustainable. They play a crucial role in the research and development of EV technology and the transition to more sustainable transportation options.

Keywords —electric vehicle , PMSM

1. Introduction

The increasing interest in electric vehicles (EVs) is driven by the need for sustainable transportation solutions to combat environmental issues and reduce our dependence on fossil fuels. Mathematical modeling and simulation play a pivotal role in the development, analysis, and optimization of electric vehicles. These techniques enable engineers, researchers, and policymakers to gain a deeper understanding of EVs and their components, facilitating the advancement of this transformative technology. This introduction provides an overview of the importance and applications of mathematical modeling and simulation in the context of electric vehicles.

1. The Growing Significance of Electric Vehicles:

With concerns over climate change and air quality, electric vehicles have gained momentum as a cleaner and more energy-efficient alternative to internal combustion engine vehicles. Governments, industries, and consumers are increasingly investing in and adopting EVs.

2. The Complexity of Electric Vehicle Systems:

Electric vehicles are complex systems that incorporate a variety of components, including batteries, electric motors, power electronics, and sophisticated control systems. Efficiently managing the interactions among these components is crucial for optimal vehicle performance.

3. The Role of Mathematical Models:

Mathematical models are mathematical representations of real-world systems. In the context of EVs, these models are used to describe and simulate the behavior of various components and subsystems, allowing engineers to predict, analyze, and optimize performance.

4. Benefits of Mathematical Modeling and Simulation:

A well-constructed mathematical model provides numerous advantages, including:

Performance Prediction: Models can predict how an EV will behave under different operating conditions, aiding in design and optimization.

Efficiency Enhancement: By simulating various scenarios, models help identify strategies to improve energy efficiency, extend range, and enhance overall performance.

Safety Analysis: Models enable engineers to assess and address safety concerns, such as thermal management, crash dynamics, and component stress analysis.

Cost Reduction: By simulating and testing different designs and components virtually, costs can be significantly reduced compared to physical testing.

5. Key Aspects of Modeling and Simulation: Modeling and simulation encompass various aspects of EVs, including battery behavior, vehicle dynamics, powertrain performance, energy consumption, charging infrastructure, environmental impact, and human-machine interaction.

6. The Interdisciplinary Nature of EV Modeling:

The development of EVs and their mathematical models require an interdisciplinary approach that combines knowledge from fields such as electrical engineering, mechanical engineering, computer science, materials science, and environmental science.

7. Implications for Sustainability and Policy:

Modeling and simulation have a broader impact on sustainability and policy development. These tools can be used to assess the environmental impact of EVs, evaluate infrastructure requirements, and shape government policies and incentives.

2. Basic Model of the System.

The motor drive consists of four main components, the PM motor, inverter, control unit and the position sensor. The components are connected as shown in Figure 1.

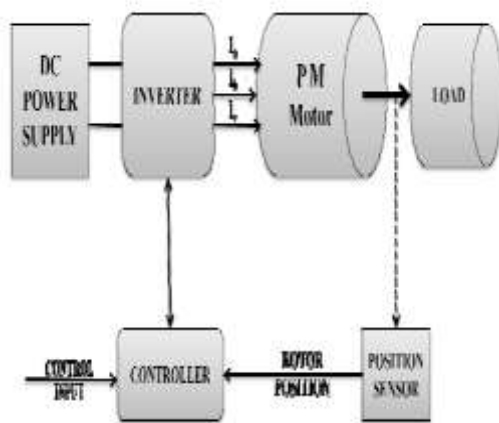

Figure 1: Schematic of the Drive System

The main components of the system are:

1. Permanent Magnet Synchronous Motor

Equivalent circuits of the motors are used for study and simulation of motors. From the d-q modeling of the motor using the stator voltage equations the equivalent circuit of the motor can be derived. Assuming rotor d axis flux from the permanent magnets is represented by a constant current source as described in the following equation

$\lambda_f = L_{dm} i_f$ illustrated in the below Figure 2

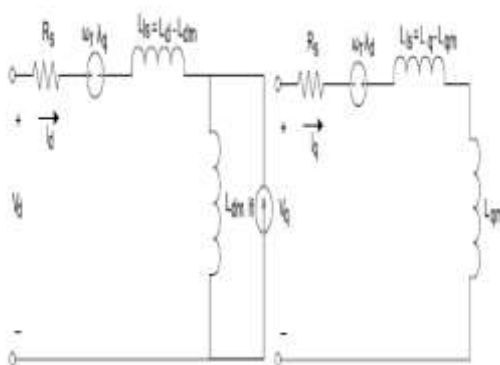

Figure 2: Permanent Magnet Synchronous motor Electric Circuit without Damper Windings

Detailed modeling of PM motor drive system is required for proper simulation of the system. The d-q model has been developed on rotor reference frame as shown in figure3. At any time t , the rotating rotor d-axis makes an angle T with the fixed stator phase axis and rotating stator mmf makes an angle α with the rotor d-axis. Stator mmf rotates at the same speed as that of the rotor.

The model of PMSM without damper winding has been developed on rotor reference frame using the following assumptions:

1. Saturation is neglected
2. The induced EMF is sinusoidal.
3. Eddy currents and hysteresis losses are negligible.
4. There are no field current dynamics.

3. Review of research paper

Y Mastanamma [1] In this paper road speed and torque values are taken and simulated using MATLAB/Simulink. The battery voltage required is calculated and the torque and speed conditions during motoring and regeneration were simulated to determine the energy flow and performance of the drive. This simulation results can be used for electric vehicle application

T.A.T. Mohd, M.K.Hassan[2] The EV's performance depends on the performance of the controller in removing error from the system. This work utilized a simple controller to maintain the

identical input–output power of battery and the P-I controller to compensate for the voltage error. The design of the EV model presented in this paper is indeed a basic model. There are still many opportunities for augmentation in order to establish a good EV model which will form the foundation for further research and development. Modeling and simulation are very important for automotive designers in order to find the best energy control strategy and exact component size, and to minimize the use of energy, because prototyping and testing are expensive and complex operations. Good design leads to a good compromise among flexibility, model simplicity, computational load and detailed representation of the components

Shivangi Kaushik [3] Proposed EV wheel drive system which is having individual front and rear control, improves the EV performance such a torque and speed stability, steer ability, drivability, and safety at low speed and high-speed operations. Also, the wheel drive systems were founded in such a way that above stated EV performance requirements attained more efficiently. The drive systems are also successfully synchronized in such a way that, if in some adverse conditions torque generated from the front wheel drive is found insufficient to drive the EV at desired speeds at the same time rear wheel drive system provides the adequate torque to the EV. In this work, firstly this synchronization and controlling of the drive system are achieved by conventional un-optimized PI controllers. Then later on the performance of drive controllers are further increased by the help of WOA along with DTC. The simulation results also show the effectiveness of used optimization over PI controllers. Optimized EV system model achieves stable speed and torque in starting and normal running mode operations very quickly. Also, the results with WOA optimization are very accurate as compare to un-optimized controls. Thus the implementation of WOA in EV wheel drive control system is found successful.

Ram N. Hajare and Archana G. Thosar[4] The mathematical model of Permanent Magnet motor drive system using field oriented control is developed. A speed controller has been designed successfully for closed loop operation of the Speed Control of Permanent Magnet Synchronous Motor

so that the motor runs at the commanded or reference speed. The fast speed response validates the advantages of Permanent Magnet Synchronous motor. Reference and actual torque produce by the motor.

Aishwarya Aptel, Rahee Walambe[5]The main contribution includes the development of each and every block of a PMSM from first principle. Also Park's transformation and modified Park transformation are studied and their subsequent simulink models are developed. The complete vector control scheme is implemented by the authors and is tested with both these types of transformation.

PMSM Model and its subsequent Matlab- Simulink implementation gives satisfactorily results. The model was tested with both modified Park's and Original Parks Transformation methods. Both techniques of transformations give similar results. This model can be used for further development. The model developed follows the standard mathematical relationships. All the control equations governing the dynamic model are kept intact. This model gives expected results in simulation. The same scheme when implemented in DSP based hardware, gives good speed control in both sensor-less and sensor operations

4. Result

Figure.3 shows the PMSM model, which was constructed according to the state equations Conversion between mechanical and electrical speed with an amplitude of 220V and a frequency of 50Hz (ie an angular velocity of $100\dot{\gamma}$ [rad/s]). is determined by relation (The model is powered by a three-phase generator

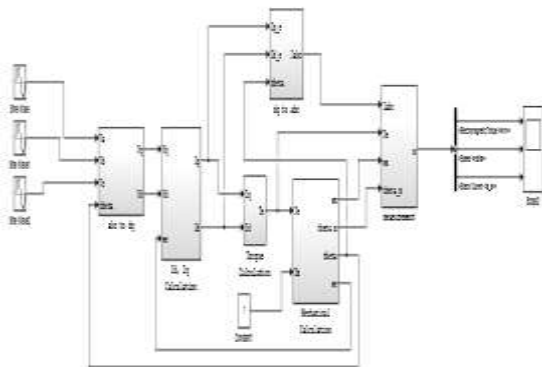

Figure 3. Simulation Of Mathematical Models of PMSM Motor

The simulation of the model shown in Figure 4 is without damping and only the load changes. That's it changes with a jump in time of 0.2s from a value of 0 to a value of 0.1Nm. On the following ones The figures are graphical responses of motor currents, speed and torque. For clarity only the current through winding a is shown in Figure 10.6, because the waveforms of the other currents are the same both in size and frequency, they are just shifted by 120°

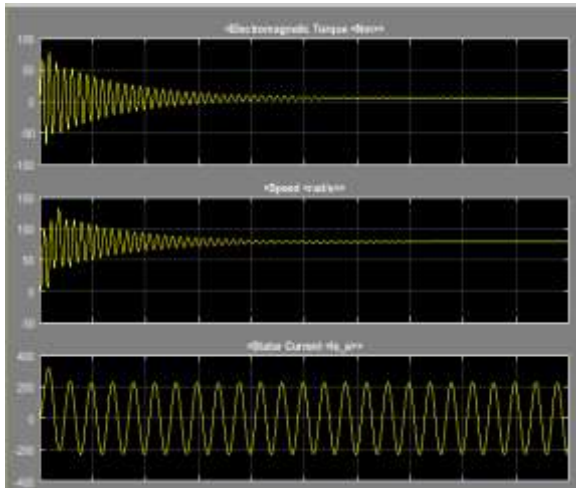

Figure 4 Waveform of Speed , torque & Stator Current

5. Conclusion

The main goal of this work was to describe the basic properties and behavior synchronous motor and build its mathematical model. This mathematical model was used to build the simulation scheme. In the first part of the project, the basic properties of synchronous are represented engine. The basic ability and at the same time probably the biggest advantage of synchronous. In conclusion, mathematical modeling and simulation are fundamental tools in the research, development, and deployment of electric vehicles. As the world continues its transition toward cleaner and more sustainable transportation solutions, these techniques will play a critical role in shaping the future of the automotive industry and addressing the global challenges of energy consumption and environmental sustainability. This series of articles will delve deeper into the various aspects of mathematical modeling and simulation in the context of electric vehicles, providing a comprehensive understanding of their applications and benefits. considered

Future scope

Permanent Magnet Synchronous Motor (PMSM) in electric vehicles (EVs) is continuously evolving and holds promising future prospects. Here are some potential future developments and areas of focus in this field: Develop and implement advanced control strategies for PMSM motors in EVs. Model Predictive Control (MPC) and artificial intelligence-based control methods, such as reinforcement learning, could be explored to optimize motor performance further

References

1. Y Mastanamma , Dr M Aruna Bharathi. “Electric Vehicle Mathematical Modelling and Simulation Using MATLAB-Simulink”. IOSR Journal of Electrical and Electronics Engineering (IOSR-JEEE)Volume 12, Issue 4 Ver. I (Jul. – Aug. 2017), PP 47-53
2. T.A.T. Mohd , M.K. Hassan ,2 and WMK. A. Aziz “Mathematical Modeling And Simulation Of An Electric Vehicle”, Journal of Mechanical Engineering and Sciences (JMES)Volume 8, pp. 1312-1321, June 2015.
- 3 Shivangi Kaushik,“ Modeling and Simulation of Electric Vehicle to Optimize Its Cost and Range”
International Journal of Engineering and Advanced Technology (IJEAT)Volume-8 Issue-6, August 2012
- 4Ram N. Hajare and Archana G. Thosar. “Modeling and Simulation of Permanent Magnet Synchronous Motor using MATLAB”, International Journal of Electrical Engineering. Volume 7, Number 3 (2014), pp. 413-423

5Aishwarya Apte, Rahee Walambe, Vrunda Joshi, Kirti Rathod and Jaywant Kolhe
,"Simulation of a Permanent Magnet Synchronous Motor using Matlab-Simulink" ,978-1-4799-5364-6/14/\$31.00 ©2014 IEEE