

MICROCONTROLLER-INTEGRATED GSM ALERTS FOR INTELLIGENT VOLTAGE TRIP IN DISTRIBUTED LOADS

Ms. B Sravanthi¹, Mr. V Ravikumar², Mr. A Soddulu³

¹²³Assistant Professor

Department of Electrical & Electronics Engineering,
Visvesvaraya College of Engineering & Technology, Hyderabad

ABSTRACT:

The main goals of this project are to alert the relay to power imbalances so that electrical home appliances and industrial equipment are protected from over- and under-voltage situations. Because electronic devices are more aware of different power sources, there is a greater chance of damaged devices. In this instance, shielding the instrument with a different power requires an extra shield mechanism. Integrated circuits using a voltage comparator determine whether the relay system trips when the voltage fluctuates above or below the predefined value. The primary advantage is that it shields the three-phase apparatus from power changes caused by single-phase and ac power waveforms. It may potentially be able to identify and guard against earth faults in the near future.

I.INTRODUCTION

At this time the main issue in the factory as the same as the home is instantly over-voltage and under-voltage which outcomes harm the instruments. Equipment load more and more in-home, as same as others, uses and the equipment so conscious to power variations. In this forecast focal point to defend the instruments in overvoltage and under-voltage and other power condition complications. In the power system, unwanted situations are short circuit, over-voltage, and under-voltage. The capability of the shield equipment is demand not only for profitable purposes but for the best system. An under-voltage situation comes if the power

decreases ostensible power by 10% for longer than one minute. This situation is the short the circuit and under-voltage position. Less duration intermittent offer decline will less anyplace from 0.5 to 1 minute. Over-voltage could be a state of affairs whenever a bigger than meant electrical phenomenon happens by a conductor. Leading to excessive generation of warmth, also the chances of fireplace and harm them instrumentally. Owed to the constant damage done by variations in the voltage offer, there's dire have to be compelled to address the matter. Over different alternations, that offer rise to make of an instrumentally to safeguard the attached masses opposite below power after below power, and over-voltage shield is required in the middle of the offer terminal and also the instrument.

II.LITERATURE SURVEY

The sun rays fall on the solar cell in some particular direction then only we get maximum output, The solar cells output depends on the intensity of sunlight and the angle of incidence. Hence the solar cells are rotated in the direction of sun position where we get maximum efficiency. solar tracker is the best for receiving maximum radiation. According to the movement of sun by moving the solar panel we can always receive the maximum radiation. Solar panels are used convert into light energy into electrical energy. Efficient Solar Power generation System using moving panel is a efficient power generating system using sun light. Total four sensor are used two sensors is E-W and other

two sensor is N-S directions to sense the direction of maximum intensity of light. The difference between to the outputs of the sensors is given to the microcontroller (PIC18F877A). Microcontroller is used to process the input voltage from the parallel circuit and control the direction in which the motor has to be rotated so that it will receive maximum intensity of light from the sun. The power generated for this process is then stored in a lead acid battery. The proposed a system provides a indication of their relative angle to the sun by comparing with predefined measured readings. By using this method, sufficiently perpendicular angle the solar tracker was successfully maintained a solar array to the Sun.

III. DESIGN OF HARDWARE

This chapter briefly explains about the Hardware. It discuss the circuit diagram of each module in detail.

ARDUINO UNO

The Arduino Uno is a microcontroller board based on the ATmega328 (datasheet). It has 14 digital input/output pins (of which 6 can be used as PWM outputs), 6 analog inputs, a 16 MHz ceramic resonator, a USB connection, a power jack, an ICSP header, and a reset button. It contains everything needed to support the microcontroller; simply connect it to a computer with a USB cable or power it with a AC-to-DC adapter or battery to get started.

The Uno differs from all preceding boards in that it does not use the FTDI USB-to-serial driver chip. Instead, it features the Atmega16U2 (Atmega8U2 up to version R2) programmed as a USB-to-serial converter. Uno board has a resistor pulling the 8U2 HWB line to

ground, making it easier to put into DFU mode. Arduino board has the following new features:

- 1.0 pin out: added SDA and SCL pins that are near to the AREF pin and two other new pins placed near to the RESET pin, the IOREF that allow the shields to adapt to the voltage provided from the board. In future, shields will be compatible both with the board that use the AVR, which operate with 5V and with the Arduino Due that operate with 3.3V. The second one is a not connected pin, that is reserved for future purposes.
- Stronger RESET circuit.
- Atmega 16U2 replace the 8U2.

"Uno" means one in Italian and is named to mark the upcoming release of Arduino 1.0. The Uno and version 1.0 will be the reference versions of Arduino, moving forward. The Uno is the latest in a series of USB Arduino boards, and the reference model for the Arduino platform; for a comparison with previous versions, see the index of Arduino boards.



Fig: ARDUINO UNO
POWER SUPPLY:

The power supplies are designed to convert high voltage AC mains electricity to a suitable low voltage supply for electronic circuits and other devices. A power supply can be broken down into a series of blocks, each of which performs a particular function. A d.c power supply

which maintains the output voltage constant irrespective of a.c mains fluctuations or load variations is known as “Regulated D.C Power Supply”.

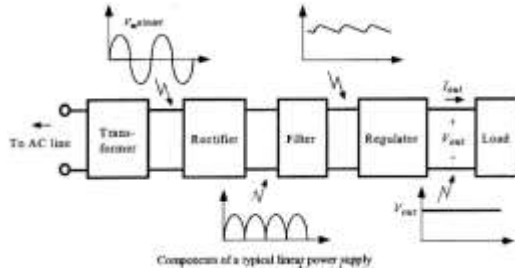

Fig: Block Diagram of Power Supply

LCD DISPLAY

A model described here is for its low price and great possibilities most frequently used in practice. It is based on the HD44780 microcontroller (Hitachi) and can display messages in two lines with 16 characters each. It displays all the alphabets, Greek letters, punctuation marks, mathematical symbols etc. In addition, it is possible to display symbols that user makes up on its own. Automatic shifting message on display (shift left and right), appearance of the pointer, backlight etc. are considered as useful characteristics.

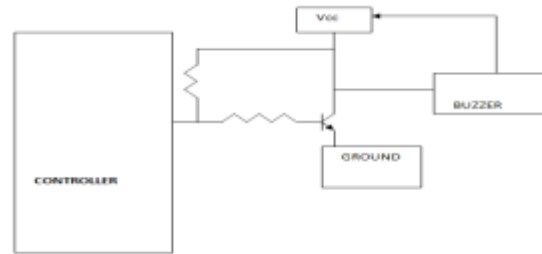

Fig: LCD

BUZZER

Digital systems and microcontroller pins lack sufficient current to drive the circuits like relays, buzzer circuits etc. While these circuits require around 10milli amps to be operated, the microcontroller’s pin can provide a maximum of 1-2milli amps current. For this reason, a driver

such as a power transistor is placed in between the microcontroller and the buzzer circuit.



WIFI MODULE:

The **ESP8266** is a low-cost Wi-Fi microchip with full TCP/IP stack and microcontroller capability produced by Shanghai-based Chinese manufacturer, Espressif Systems.^[1]

The chip first came to the attention of western makers in August 2014 with the **ESP-01** module, made by a third-party manufacturer, Ai-Thinker. This small module allows microcontrollers to connect to a Wi-Fi network and make simple TCP/IP connections using Hayes-style commands. However, at the time there was almost no English-language documentation on the chip and the commands it accepted.^[2] The very low price and the fact that there were very few external components on the module which suggested that it could eventually be very inexpensive in volume, attracted many hackers to explore the module, chip, and the software on it, as well as to translate the Chinese documentation.^[3]

The **ESP8285** is an ESP8266 with 1 MiB of built-in flash, allowing for single-chip devices capable of connecting to Wi-Fi.^[4]

The successor to these microcontroller chips is the ESP32.



RELAYS

We know that most of the high end industrial application devices have relays for their effective working. Relays are simple switches which are operated both electrically and mechanically. Relays consist of a n electromagnet and also a set of contacts. The switching mechanism is carried out with the help of the electromagnet. There are also other operating principles for its working. But they differ according to their applications. Most of the devices have the application of relays.

The main operation of a relay comes in places where only a low-power signal can be used to control a circuit. It is also used in places where only one signal can be used to control a lot of circuits. The application of relays started during the invention of telephones. They played an important role in switching calls in telephone exchanges. They were also used in long distance telegraphy. They were used to switch the signal coming from one source to another destination.

The basics for all the relays are the same. Take a look at a 4 – pin relay shown below. There are two colours shown. The green colour represents the control circuit and the red colour represents the load circuit. A small control coil is connected onto the control circuit. A switch is connected to the load. This switch is controlled by the coil in the control circuit. Now let us take the different steps that occur in a relay.

IV. BLOCK DIAGRAM:

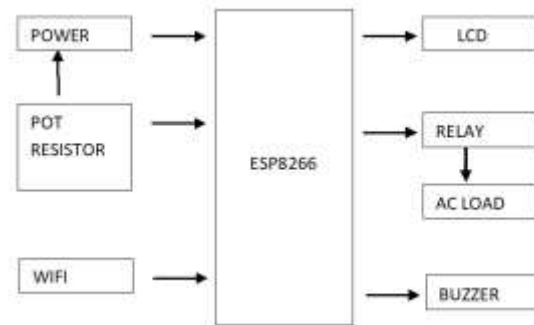

Working: Air conditioning supply is ventured down to 12 V by utilizing a stage down transformer. The AC supply is changed over to DC supply through scaffold rectifier. The supply is then sifted by capacitors associated crosswise over rectifier to decrease music. At that point the unregulated supply is then given to voltage controller whose yield is given to the comparators IC LM324 and transfer as supply as shown in fig. 15. The unregulated supply from connect rectifier is set to set 1 and set 2 as info. The set 1 and set 2 are potentiometer ckt.1 and potentiometer ckt.2 individually associated with comparators IC LM324 as information. Further, the comparators and load are associated with hand-off. At whatever point there is overvoltage or under voltage the comparators look at the set conditions and gives the flag to the hand-off and hand-off outings and the heap will turned off. With the goal that it secures the electrical apparatus.

- When the line voltage is lower than 180V, the voltage at the upsetting terminal (stick 6) of operational enhancer N2 is beneath the voltage at the nonmodifying terminal (6V) as shown in fig. 16. Subsequently the yield of operational speaker N2 goes high and it empowers the hand-off through transistor T1. The AC supply is separated from the framework and electrical apparatuses kill.
- Subsequently the machines

are secured against under-voltage. IC1 is wired for a directed 12V supply. • The transfer invigorates in two conditions: in the first place, if the voltage at stick 3 of IC2 is past 6.8V, and second, if the voltage at stick 6 of IC2 is lower than 6V. • Over-voltage and under-voltage levels can be adjusted utilizing sets VR1 and VR2, individually. 3.5 Hardware Implementation • It includes the points of interest of the arrangement of outline details. The equipment plan comprises of, the choice of framework segments according to the prerequisite, the points of interest of subsystems that are required for the total usage of the framework has been completed. It includes the part determination, segment portrayal and equipment subtle elements of the framework outlined.

V.CONCLUSION

During this endeavor, the goal of designing and creating reduced undervoltage and overvoltage-current shield equipment was accomplished. According to the top study, the consequences of both under- and over-voltage are similar and might affect clients as well as other people. System should thus be protected by a specific shield. As a result, the system uses a comparator and a relay to cancel the connection offer as soon as an under- or overvoltage drawback occurs. When the input offer falls inside the designated present voltage, the device supplies load to the connected load, shielding the output linked masses from unwarranted damage. The apparatus is found to be economical, easily maintained, and repairable.

REFERENCES:

1. J.B GUPTA (2018) A COURSE IN POWER SYSTEMS, PART-III: Switchgear and Protection, Chapter-9.
2. ROBERT L. BOYLESTAD, LOUIS NASHESKY (2015) Electronic Devices and Circuit Theory 11th Edition, Chapter-10.

3. "IEEE Recommended Practice for Monitoring Electric Power Quality," IEEE Std. 1159-1995, June 1995.

4. Girish Chandra Thakur, Kumar Shantanu Kaushal, Manish Ranjan, Sandip kumar Gupta. "Implementation of single phasing, over voltage, under voltage, Protection of Three Phase Appliances without using Microcontroller", Int. journal of Engineering Research and Applications,ISSN:2248-9622, vol. 5, Issue 5, (Part-6), pp.110-115,May 2015.

5. Sourav Ghosh, Soumik Bakshi, saurav Ghosh, Rahul kundu, Indrajit Koleys. "Development of a low cost under voltage and over current protection device", Int. Journal of Advance Research in Electrical, Electronics and Instrumentation Engineering, ISSN: 2278-8875, vol.5, Issue 5, May 2016.

6. Gorkshanath Bhosale, Aakash Vakhare, Abhishek Kaystha, Amol Aher, Vishal Pansare. "Overvoltage, Undervoltage, Protection of Electrical Equipment", Int. Research Journal of Engineering and Technology(IRJET), ISSN: 2395- 0056, vol.5, Issue 2, Feb 2018.