

METHODS FOR SIMULATORY ANALYSIS OF THE HEXA ALLEN WRENCH

¹Nidigonda Gopikrishna,²Dr.B.Ravindar

¹Assistant Professor,²Associate Professor

Department Of Mechanical Engineering

Sree Chaitanya College of Engineering, Karimnagar

ABSTRACT

This little portable instrument is used to turn screws and bolts with hexagon-shaped sockets. Surprisingly, these instruments are not very new, despite the common belief that Allen keys are. In the middle to late 1800s, the idea of a screwdriver with a hexagonal form emerged and gained traction. They are now offered in various sizes. Our analysis indicates that there are far more significant issues with the current items than with ours. One of the most frequent issues we discovered was that the current items were quite hefty and lacked storage space. In contrast to what we provide, we supply a very tiny allen key. In addition to being simple to use, our product offers our customers an abundance of advantages. A methodology is a way of planning, gathering, and evaluating data in order to provide proof for a research. My project aims to lessen the load on users. We use AISI 8650, SAE-AISI 6150, alloy heavy duty steel 304, and mild steel round bars in addition to existing aluminium, stainless steel, and mild steel round bars. ANSYS 18.0 workbench was used to do a statically-analyzed 3D parametric model of the hexa allen key, which was created using SOLIDWORKS workbench. Lastly, a material recommendation based on end user perspective and mechanical behaviour.

I. INTRODUCTION TO HEXA KEYS

Hex keys, commonly known as Allen keys/wrenches in the UK and various other countries, are a very simple hand tool of the general spanner and socket family, used for tightening and loosening hexagonal bolts and other compatible fasteners. Hex keys are most often encountered as a single piece of steel formed into a small L-shape, although there are a number of variations on this basic format available to buy from many different manufacturers and suppliers.



Figure 1 different sizes of allen key set

Hex keys or Allen wrenches are basic and highly versatile fastening/driving tools, which is largely why they're so very widely used across an extensive array of applications and product categories today. Most professional or hobbyist DIY enthusiasts - indeed, anyone who owns a reasonably well-stocked toolbox of any kind - will more than likely have a few different sizes of hex keys (or possibly even complete hex key sets) knocking around in it somewhere.

In fact, their use is now so widespread that the inclusion of a free hex key with flat-pack furniture, bicycles and other products requiring quick straightforward assembly is now an extremely common practice (although, unsurprisingly, the quality of such giveaway tools is often very questionable). A solid, high quality hex wrench or Allen key set will potentially last many years and prove useful time and time again, whereas lower-grade 'freebie' tools are much more likely to be severely limited in both their adaptability to other tasks and overall longevity in frequent use.

In this guide, we'll look at some of the basic types of hex keys available to buy on the current market, as well as assessing the relative pros and cons of each, and offering a few pointers towards best practice when it comes to successful hex key sizing choices and uses.

TYPES AND SHAPES OF HEX KEY

There are numerous Allen key types sold on today's market, many of which adhere very closely to the fundamental early design blueprint. However, some manufacturers do offer additional features or design flourishes, intended as an update to the basic model of a one-piece, hexagonal shaft steel tool. Depending on the brand or supplier, these might include slightly more exotic versions of the simple hex wrench, such as:

- Folding hex keys
- Straight hex keys
- L-shaped hex keys
- T-handle hex keys
- Ball end hex keys

HEX KEY SIZES

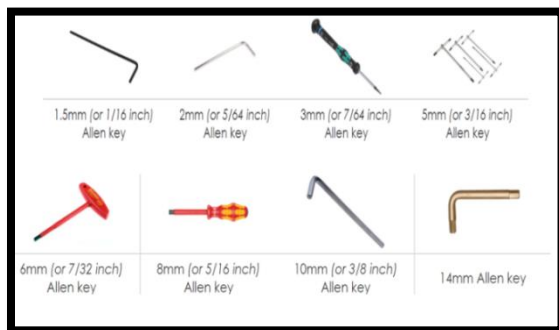

Figure 2 different hex key sizes

USES FOR ALLEN KEYS

Here are 5 uses for Hex key that will change the way you build, repair, and maintain in the workshops.

- **BICYCLE REPAIR**– These are the dominant tools used for bike repairs and size adjustments. The wide range of sizes allows them to be used in different applications, and their compact size makes them easy to carry. If you are a frequent rider you can pick a set of folding hex keys.
- **FURNITURE REPAIRS**– Allen screws are an essential piece of hardware for securing furniture at its place. It allows assembling the furniture without adding any unnecessary bulk pieces. Their compact design makes them discrete in appearance and strong in fastening. Since furniture pieces can have tight spaces and

require long reach, you can use a set of long arm Hex keys.

- **CARS AND MOTORCYCLES**– You would need an Allen key set for the proper maintenance of your car. Allen keys are helpful while accessing the areas under the seat, and places under the dash like behind the glove compartment. T-handle Hex wrenches are recommended for cars and motorcycles repair.
- **TOOLS**– Apart from other uses, Allen keys can also be helpful in maintaining and repairing heavy tools and machinery. Drill bits rely on it to secure the bit into place. Similarly, power saws of all varieties require Allen keys to change blades or for minor adjustments. Short arm Allen keys are mostly used to perform these tasks.
- **ELECTRONICS**– Allen wrenches are becoming very popular with people dealing with repairing and maintaining electronics. As electronics are becoming more and more compact in size, Allen keys are being used to support their size. Computers and large television screens are held together with these screws from the backside. You can buy torque wrenches for this purpose. They are the main items in every electrician's toolbox.

II. LITERATURE REVIEW

1. Although the hex socket screw driver concept may have originated as early as the 1860s or 1890s, it is likely that the first such screws were not produced until around 1910. Internal-wrenching square and triangle types, or square and triangular sockets, are confirmed to have been included in a flurry of patents for alternative drive types in the 1860s to the 1890s in the U.S
2. **RYBCZYNSKI (2000)**. However, he explains that these were patented but not manufactured due to the challenges and cost of doing so at the time.
3. **P. L. ROBERTSON OF MILTON, ONTARIO**, was the first to commercialize the square socket in 1908 after he developed and received a patent for an effective cold forming technique that made use of the proper material and die design. William G. Allen also received a U.S. Patent for a process for cold-forming screw heads around a hexagonal die in 1909–1910. There are 1910 print advertisements for the "Allen safety set screw" produced by Hartford, Connecticut-based Allen Manufacturing Company.
4. **HOWARD T. HALLOWELL SR.**, the founder of the Standard Pressed Steel Company (SPS; now SPS Technologies, Inc.), provides a version

of events[4] in his book in which SPS independently created a hex socket drive in 1911. As a result, the Unbrako product line was born. The Allen patent from 1910 or the Allen safety set screw product line aren't mentioned in this Hallowell narrative. Hallowell does, however, note the same source of inspiration mentioned in relation to Allen for a wave of hex socket head adoption starting with set screws and continuing with cap screws. Getting headless set screws onto the pulleys and shafts of the line shafting was the goal of this industrial safety campaign, which was a component of the greater Progressive Movement.

5. **ROBERTSON'S CANADIAN** Due to a cost issue, SPS decided to buy its first screw machine and start producing its own screws, which prompted the company to start selling fasteners (for which it later gained notoriety in the metalworking sectors). While, we experimented with a screw that had a square hole like the British screw, but we quickly realized that these would not be acceptable in this country [the United States]," stated Hallowell. We therefore made the decision to add a hexagon socket to the screw. It seems likely that SPS would have had to licence Robertson's patent, which would have contradicted SPS's goal of lowering the cost of its internal-wrenching screws. Hallowell does not go into detail about why SPS determined that the square hole "would not be acceptable in this country."
6. Most laypeople likely first encountered the painful hexagon drive during World War II, with its extraordinary push for industrial production of all kinds. (Popular Science noted in 1946 that "cap screws and setscrews with heads recessed to take hexagonal-bar wrenches are coming into increasing use."

PROBLEM STATEMENT

This Allen key is used to drive bolts and screws with hexagonal sockets in their heads. According to our research, we have a lot of problematic issues compared to existing products. One of the most common problems we found is doesn't have a storage space. When compared to our products, we provide a high-end Allen key. Not only it is convenient for storage, it is also easy to use for everyone. Secondly, the existing Allen key price is expensive to obtain. This is because you have to spend a lot of money to

buy different types and sizes of Allen keys. Here, we focus on the financial sector.

Our product is not only easy to use, but they also can give too many benefits to our buyers. This is because, one of the things we created, has come in many different sizes and shapes. Isn't this cheaper for all? A low price but can buy all kinds of sizes and shapes of Allen key. Third, we found that some existing Allen keys is in poor quality. For example, the material used is fragile and rusty. We have replaced existing materials with better quality materials. Among the non-corrosive iron is nonferrous metal. Nonferrous metal means that it is a metal that contains little or no carbon at all. Examples: Brass, Aluminum, Zinc, Lead, Bronze, Silver, etc. Lastly, the main reason of this product to be create is because to solve all the problems that the users has. We also got a problem when we want to use this Allen key in mechanical workshop but the Allen key that we take is not the same size, so we need to find it again. It will waste our time.

OBJECTIVE PROJECT

The studies had explained about its origin of ideas and inspirations. All the stated objectives can be achieved through problem statement. Thus, with this adjustable Allen key we can create an innovation that gives benefits to everyone. This adjustable Allen key is not only useful for Allen key user but everyone also can use it as well. This is because this adjustable Allen key is portable and not heavy at all. The conclusion is, this adjustable Allen key can give a good impact and advantages to the user. We believe that everyone will go get this Allen key for their house or anything else.

The objectives to this research are:

- I. Create a better Allen key among material point of view
- II. Make a lighter Allen key to carry out
- III. Easy to bring anywhere since the Allen key can keep in the small place such as in the pocket

III. METHODOLOGY

A methodology is a plan-of-attack, especially when that plan-of-attack is used repeatedly. This might be obvious, but the word methodology is related to the word method. In fact, a methodology is a system of methods followed consistently. Scientists, for example, use various methodologies as they perform

experiments. It might seem like the world is nothing but chaos and disorder. But actually, sometimes there is a method to this madness. And sometimes there's a methodology. In this chapter, there will be a lot of information about the process and journey through out the making of our final project.

There will be flow chart showing the process of us making the whole project. This flow chart will explain the processes we took. However, in this chapter, we also will show 3 methods we researched to carry our final year project. Although, these 3 methods have it own pros and cons and it will be explained individually by the teammates. Methodology is a method and technique for designing, collecting and analyzing data to produce evidence that supports a study. Methodology describes how a problem is studied and why a method and technique is used. Methodological studies are a rigorous planning in the course of this semester. In order to facilitate the final project journey, the methodology must be set as best as possible. With this, every step of the journey of this project will not fall short of the set path or more precisely the end result of the study will meet the needs of the problem to be solved. Therefore, it is very important to know and understand in depth each of the processes involved in structural engineering studies.

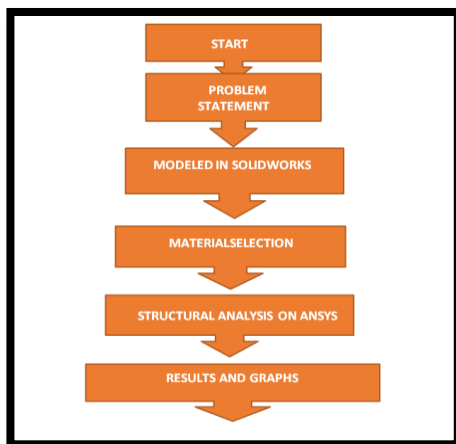

Figure 3 methodology flow chart

MATERIAL SELECTION

The process of material selection is one of the most important processes in this final year project. The main factor of material selection is to discuss and finalized which materials that will be use in the project in order to avoid wasting of money and time.

The material selection need to be done precisely so that the risks could be avoided.

- **ALUMINIUM ROUND BAR**

Aluminum is an extremely versatile metal with a number of advantages; it is recognized for being both lightweight and flexible. It can be cast, melted, formed, machined and extruded meaning that it can be manufactured into a variety of shapes and then subsequently fabricated to suit a whole variety of uses.

- **STAINLESS STEEL ROUND BAR**

Stainless Steel Round Bar also known as marine grade, provides corrosion and pitting resistance in more aggressive environments stainless bar are used for products that require very high corrosion protection. Higher levels of molybdenum and nickel increase corrosion and surface pitting resistance. stainless steel round bar exhibits the same high strength, toughness and workability as 304 bar.

- **SAE-AISI 6150 Cr-V-Steel ALLOY**

SAE-AISI 6150 steel is an alloy steel formulated for primary forming into wrought products. 6150 is the designation in both the SAE and AISI systems for this material. G61500 is the UNS number. It has the highest embodied energy among the SAE-AISI wrought steels in the database.

- **HEAVY DUTY STEEL 304**

Steel is an alloy – that is, a metal made from blending so-called alloying elements into a base metal – and it provides a quite literal backbone for modern industry. Steel is composed of primarily carbon and iron, with other trace elements that can give steels unique properties from each other. One class of steels is known as the stainless steels, which utilizes chromium to reduce the usual corrosion experienced by most iron-based materials. This article will explore the most common stainless steel, 304 steel, and will investigate its physical, mechanical, and working properties. Designers will gain a better understanding of what this material is, how it works, and where 304 steel is applied in industry so that they can potentially select this material for use in their own projects.

- **AISI 8650**

AISI 8650 is a triple-alloy (**Nickel Chromium Molybdenum**) steel of the oil-hardening type. Its good harden ability and strength makes it suitable for many machine and tool components. This datasheet provides information on composition, physical properties, hardness,

elasticity, and tensile properties as well as fracture toughness. It also includes information on corrosion resistance as well as forming, heat treating, machining, and joining.

MILD STEEL

Mild steel is a type of carbon steel with a low amount of carbon – it is actually also known as “low carbon steel.” Although ranges vary depending on the source, the amount of carbon typically found in mild steel is 0.05% to 0.25% by weight, whereas higher carbon steels are typically described as having a carbon content from 0.30% to 2.0%. If any more carbon than that is added, the steel would be classified as cast iron.

DIMENSION OF HEXA ALLEN KEY:

A fully parametric model of HEXA ALLEN key was developed by using following standard dimensions.

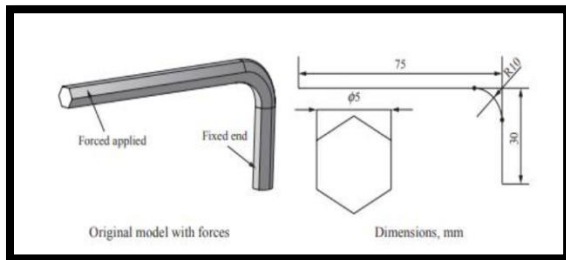

Figure 4 dimensions of hexa allen key

DESIGN CALCULATIONS:

My design is a bit different due to it being telescoping. The hex head sizes now in use are 12mm (casing), and 8mm, 5mm telescoping bits. To illustrate, if the 5mm is in the extended position, it will be locked in place with a compressive spring button (push down on the button and the smaller successive bit can slide out from the retracted position into a new hole locking in with the larger encompassing bit). Will the max stress occur on the 5mm bit or on one of the holes which lock the 12mm to the 8mm, or 8mm to the 5mm together.

DIMENSIONS:

- 75 mm long arm: Assume uniform diameter.
- On short arm: 30mm length (12mm hex head)

- The 8mm bit sticks out 14.375mm from that, and the 4mm bit sticks out 5mm from that. 12mm-5mm connection: 5mm diameter hole for button. 5mm-4mm
- Connection: 2mm diameter hole for button.

Applied pressure from hand: 50N/750mm²

5N compression downward

DESIGNING OF THE MODEL:

The Hex Allen key design was developed by using SOLIDWORKS 2020 EXPLORER workbench has been completed. Using different features and sketch modules. Features like Swept boss base command most useful one by developing the model using Profile of hexagon and Sketch as a line feature. An isometric view of a hex Allen key is shown in below figure.

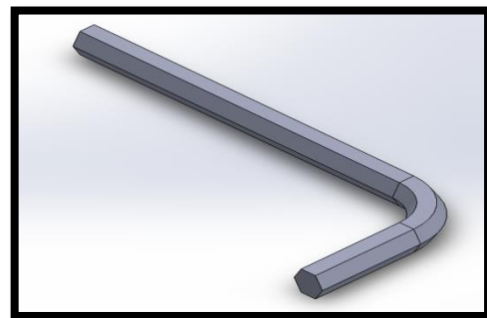

Figure 5 isometric view of hex allen key

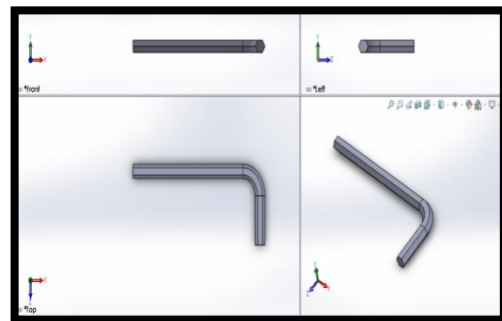

Figure 6 multi section view of hex allen key in solid works

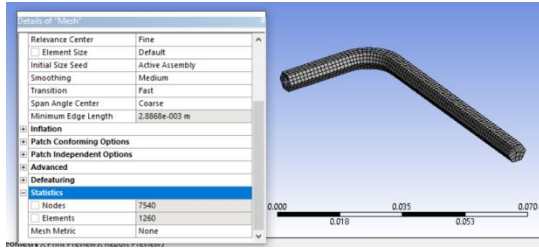

Figure 7 mesh body with nodes: 7540 and elements: 1260

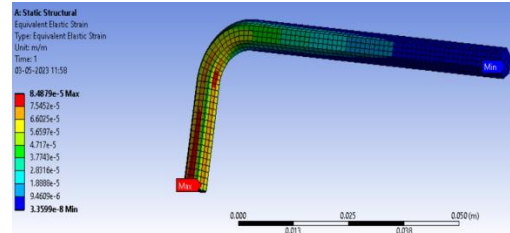

Figure 11 equivalent strain of stainless steel round bar

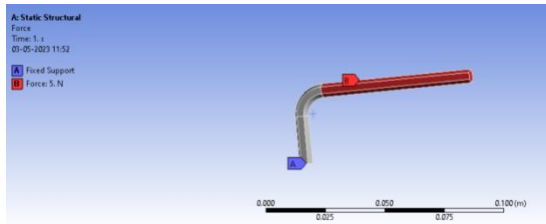

Figure 8 boundary condition

STATIC STRUCTURAL RESULTS

Here the final results of Hexa allen key performed statically in equivalent stress, total deformation and strains point of view by applying bounded conditions on all six different materials of existing Aluminum round bars, Stainless steels & mild steel round bars along with advanced SAE-AISI 6150, Alloy Heavy Duty Steel 304 and AISI 8650 materials as shown in the following tabular format.

IV. RESULTS AND DISCUSSION

The following are the static analysis results obtained by conducting simulation on ANSYS workbench at six different nodes with three different materials like Aluminum round bars, Stainless steels & mild steel round bars along with advanced SAE-AISI 6150, Alloy Heavy Duty Steel 304 and AISI 8650 materials are used.

MATERIAL	Equivalent Stress (Pa * e7)	Total deformation (m * e-5)	Equivalent Strain (* e-5)
Aluminum	1.62	1.04	8.16
Stainless steels	1.69	0.106	8.48
Mild Steel	1.62	0.987	7.76
Cr-V Steel Alloy	1.52	0.981	7.67
Heavy Duty Steel 304	1.60	1.03	8.08
AISI 8650	1.59	1.02	8.004

Table 1 static structural result

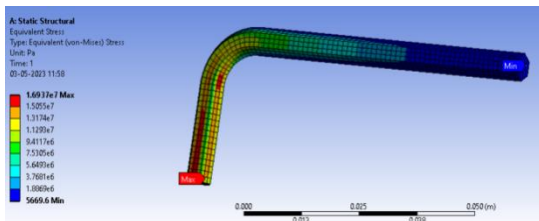

Figure 9 equivalent stresses of stainless steel round bar

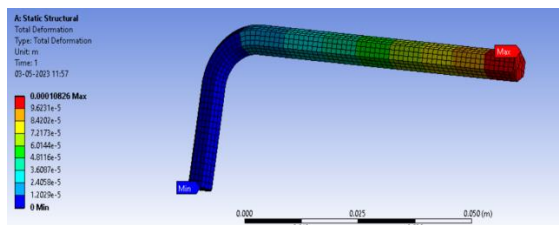

Figure 10 total deformation of stainless steel round bar

V. CONCLUSION

Hexa allen key model design created using SOLIDWORKS software. Afterwards, the Hexa Allen key model that was created in SOLIDWORKS was imported into ANSYS software to perform a modal analysis on the Hexa Allen key. This was done to verify the quality and static analysis of six distinct materials, including mild steel, stainless steel, and aluminium round bars, as well as advanced SAE-AISI 6150, Alloy Heavy Duty Steel 304, and AISI 8650 materials. Based on the acquired static structural analysis findings for six different materials under equivalent stress, strain, and total deformation, respectively. Cr-V-Steel material has superior values than these materials, as shown by the tabular depiction. After analysing round bars made of aluminium, stainless steel, and mild steel as well as advanced SAE-AISI 6150, alloy heavy duty steel 304, and AISI 8650 materials, it is finally determined that CHROME VANADIUM STEEL is a suitable material for the Hexa Allen key model.

REFERENCES

1. Avallone, E. A. & T. Baumeister III, Marks Standard Handbook for Mechanical Engineers, 9th Edition, McGraw Hill Book Company, NY, 1987.
2. American Society for Testing and Materials, Annual Book of ASTM Standards, Section 3: Metals Test Methods and Analytical Procedures, Vol. 03.01-Metals-Mechanical Testing; Elevated and Low-Temperature Tests, ASTM, Philadelphia, 1986, pp. 836-848.
3. Bannantine, J. A., J. J. Comer and J. L. Handrock, Fundamentals of Metal Fatigue Analysis, Prentice Hall Inc, New Jersey, 1990.
4. Bickford, J. H., An Introduction to the Design and Behavior of Bolted Joints, Second Edition, Marcel Dekker, NY, 1990.
5. Bickford, J. H. and S. Nassar, Editors, Handbook of Bolts and Bolted Joints, Marcel Dekker, NY, 1998.
6. Durbin, Samuel, Charles Morrow, and Jason Petti, "Review of Bolted Joints near Material Edges", Internal Sandia Memo, 2007.
7. Lindeburg, M. R., Mechanical Engineering Reference Manuals for the PE Exam, 11th Edition, Professional Publications, Belmont, CA, 2001.
8. Miller, Keith, private conversations, 2007.
9. Morrow, Charles and Samuel Durbin, "Review of the Scale Factor, Q, Approach to Bolted Joint Design", Internal Sandia Memo, 2007.
10. Musto, J. C. and N. R. Konkle, "Computation of Member Stiffness in the Design of Bolted Joints", ASME J. Mech. Des., November, 2006, 127, pp. 1357-1360.
11. National Aeronautics and Space Administration, "Space Shuttle: Criteria for Preloaded Bolts", NSTS 080307 Revision A, July 6, 1998.
12. Oberg, E., F. D. Jones, L. H. Holbrook, and H. H. Ryffel, Machinery's Handbook, 27th Edition, Industrial Press Inc, NY, 2004
13. Pulling, E. M., S. Brooks, C. Fulcher, K. Miller, Guideline for Bolt Failure Margins of Safety Calculations, Internal Sandia Report, December 7, 2005.
14. Roach, R. A, Working Draft of "Design & Analysis Guidelines for Satellite Fasteners & Flexures", 2007.
15. Shigley, J. E., C. R. Mischke, and T. H. Brown, Jr., Standard Handbook of Machine Design, 7th Edition, McGraw-Hill Book Company, NY, 2004.
16. Shigley, J. E., C. R. Mischke, and R. G. Budynas, Mechanical Engineering Design, 7th Ed., McGraw-Hill Book Company, NY, 2004.
17. Wileman, J., M. Choudhury, and I. Green, "Computation of Member Stiffness in Bolted Connections," ASME J. Mech Des., December, 1991, 113, pp. 432-437.