

SUSTAINABLE ENERGY WITH HYBRID SOLAR AND WIND POWERED UPS SYSTEMS

Mr. K Rajkumar¹, Ms. U Yojana², Mr. B Rajesh³

¹²³Assistant Professor

Department of Electrical & Electronics Engineering,
Visvesvaraya College of Engineering & Technology, Hyderabad

ABSTRACT:

This research proposes a high frequency AC link converter that is based on solar power. The majority of issues with current inverter topologies are resolved by the suggested inverter. While in resonance, the suggested inverter functions as a partial resonant converter, enabling the switches to be turned on at zero voltage. As a result, switching losses are quite small. The LC link can operate at extremely high frequencies, which reduces the size and weight of the inductor. It also has low reactive ratings and low power dissipation. This article includes a thorough design process of the prototype inverter together with the results of the simulation and experimental test.

I.INTRODUCTION

Solar power sources play important role in many of power systems. They can be used in distributed energy systems and microgrid power systems. Solar power is extracted by PV systems which provide the DC voltage as output but later we can convert this energy into suitable form with PV inverters. The inverters convert the DC voltage into AC form. Power electronics is an integral part of these distributed energy (DE) systems and adds costs as well as certain reliability issues [1]. The inverters are responsible for most of the photo voltaic (PV) systems, they are costly and complex and their current mean time to first failure is unacceptable. Sometimes inverter failures contribute to unreliable PV systems by this

producer will lose his confidence in renewable technology.

To achieve long-term success in the PV industry, new power converters with higher reliability and longer lifetimes are required [1]. In past days, inverters are designed with centralized converter-based PV system. In this, PV modules are connected to a three phase voltage-source inverter coupled with low frequency transformers. But these transformers are having large size and low efficiency. Later these are replaced by multiple-stage conversion system which includes a dc-ac voltage source inverter and a dc-dc converter [6], [9]. But this topology offered some drawbacks such as bulky electrolytic capacitors which reduce the life of inverter. Also it reduced the efficiency of overall system [2], [3]. To overcome all these problems and to achieve reliability in the inverter system, a solar based highfrequency AC-link is proposed. This inverter which overcomes most of the problems compare to existing inverters. Also it reduces the cost and size of the inverter. The proposed inverter operating at zero voltage and zero currents switching hence the losses are neglected [1], [2]. It is partially resonant converter [2], [7].

II.LITERATURE SURVEY

The sun rays fall on the solar cell in some particular direction then only we get maximum output, The solar cells output depends on the intensity of sunlight and the angle of incidence. Hence the solar cells are rotated in the direction of sun position where we get maximum

efficiency. solar tracker is the best for receiving maximum radiation. According to the movement of sun by moving the solar panel we can always receive the maximum radiation. Solar panels are used convert into light energy into electrical energy. Efficient Solar Power generation System using moving panel is a efficient power generating system using sun light. Total four sensor are used two sensors is E-W and other two sensor is N-S directions to sense the direction of maximum intensity of light. The difference between to the outputs of the sensors is given to the microcontroller (PIC18F877A). Microcontroller is used to process the input voltage from the parallel circuit and control the direction in which the motor has to be rotated so that it will receive maximum intensity of light from the sun. The power generated for this process is then stored in a lead acid battery. The proposed a system provides a indication of their relative angle to the sun by comparing with predefined measured readings. By using this method, sufficiently perpendicular angle the solar tracker was successfully maintained a solar array to the Sun.

III. DESIGN OF HARDWARE

This chapter briefly explains about the Hardware. It discuss the circuit diagram of each module in detail.

ARDUINO UNO

The Arduino Uno is a microcontroller board based on the ATmega328 (datasheet). It has 14 digital input/output pins (of which 6 can be used as PWM outputs), 6 analog inputs, a 16 MHz ceramic resonator, a USB connection, a power jack, an ICSP header, and a reset button. It contains everything needed to support the microcontroller; simply connect it to a computer with a USB cable or power it with a AC-to-DC adapter or battery to get started.

The Uno differs from all preceding boards in that it does not use the FTDI USB-to-serial driver chip. Instead, it features the Atmega16U2

(Atmega8U2 up to version R2) programmed as a USB-to-serial converter. Uno board has a resistor pulling the 8U2 HWB line to ground, making it easier to put into DFU mode. Arduino board has the following new features:

- 1.0 pin out: added SDA and SCL pins that are near to the AREF pin and two other new pins placed near to the RESET pin, the IOREF that allow the shields to adapt to the voltage provided from the board. In future, shields will be compatible both with the board that use the AVR, which operate with 5V and with the Arduino Due that operate with 3.3V. The second one is a not connected pin, that is reserved for future purposes.
- Stronger RESET circuit.
- Atmega 16U2 replace the 8U2.

"Uno" means one in Italian and is named to mark the upcoming release of Arduino 1.0. The Uno and version 1.0 will be the reference versions of Arduino, moving forward. The Uno is the latest in a series of USB Arduino boards, and the reference model for the Arduino platform; for a comparison with previous versions, see the index of Arduino boards.



Fig: 1. ARDUINO UNO

POWER SUPPLY:

The power supplies are designed to convert high voltage AC mains electricity to a suitable low voltage supply for electronic circuits and other devices. A power supply can be broken down into a series of blocks, each of which performs a particular function. A d.c power supply which maintains the output voltage constant irrespective of a.c mains fluctuations or load variations is known as "Regulated D.C Power Supply".

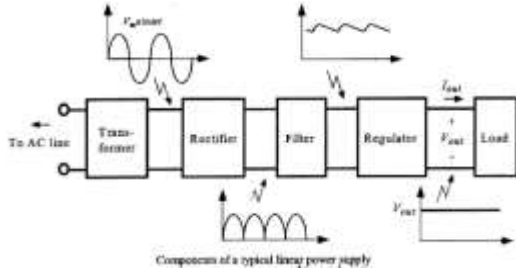

Fig:2 Block Diagram of Power Supply

LCD DISPLAY

A model described here is for its low price and great possibilities most frequently used in practice. It is based on the HD44780 microcontroller (Hitachi) and can display messages in two lines with 16 characters each. It displays all the alphabets, Greek letters, punctuation marks, mathematical symbols etc. In addition, it is possible to display symbols that user makes up on its own. Automatic shifting message on display (shift left and right), appearance of the pointer, backlight etc. are considered as useful characteristics.



Fig:3 LCD

BUZZER

Digital systems and microcontroller pins lack sufficient current to drive the circuits like relays, buzzer circuits etc. While these circuits require around 10milli amps to be operated, the microcontroller's pin can provide a maximum of 1-2milli amps current. For this reason, a driver such as a power transistor is placed in between the microcontroller and the buzzer circuit.

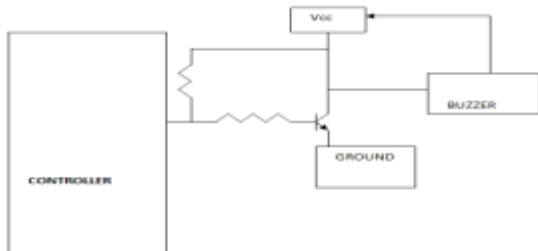

WIFI MODULE:

The **ESP8266** is a low-cost Wi-Fi microchip with full TCP/IP stack and microcontroller capability produced by Shanghai-based Chinese manufacturer, Espressif Systems.^[1]

The chip first came to the attention of western makers in August 2014 with the **ESP-01** module, made by a third-party manufacturer, Ai-Thinker. This small module allows microcontrollers to connect to a Wi-Fi network and make simple TCP/IP connections using Hayes-style commands. However, at the time there was almost no English-language documentation on the chip and the commands it accepted.^[2] The very low price and the fact that there were very few external components on the module which suggested that it could eventually be very inexpensive in volume, attracted many hackers to explore the module, chip, and the software on it, as well as to translate the Chinese documentation.^[3]

The **ESP8285** is an ESP8266 with 1 MiB of built-in flash, allowing for single-chip devices capable of connecting to Wi-Fi.^[4]

The successor to these microcontroller chips is the ESP32.



Solar panel :

Solar panel refers either to a photovoltaic (PV) module, a solar hot water panel, or to a set of solar photo voltaic modules electrically connected and mounted on a supporting structure. A PV module is a packaged, connected assembly of solar cells. Solar panels can be used as a component of a larger photovoltaic system to generate and supply electricity in commercial and residential applications. Each module is rated by its DC output power under standard test conditions, and typically ranges from 100 to 320

watts. The efficiency of a module determines the area of a module given the same rated output – an 8% efficient 230 watt module will have twice the area of a 16% efficient 230 watt module. There are a few solar panels available that are exceeding 19% efficiency. A single solar module can produce only a limited amount of power; most installations contain multiple modules. A photovoltaic system typically includes a panel or an array of solar modules, an inverter, and sometimes a battery and/or solar tracker and interconnection wiring.

Solar modules use light energy (photons) from the sun to generate electricity through the photovoltaic effect. The majority of modules use wafer-based crystalline silicon cells or thin-film cells based on cadmium telluride or silicon. The structural (load carrying) member of a module can either be the top layer or the back layer. Cells must also be protected from mechanical damage and moisture. Most solar modules are rigid, but semi-flexible ones are available, based on thin-film cells. These early solar modules were first used in space in 1958.

Electrical connections are made in series to achieve a desired output voltage and/or in parallel to provide a desired current capability. The conducting wires that take the current off the modules may contain silver, copper or other non-magnetic conductive transition metals. The cells must be connected electrically to one another and to the rest of the system. Externally, popular terrestrial usage photovoltaic modules use MC3(older) or MC4 connectors to facilitate easy weatherproof connections to the rest of the system. Bypass diodes may be incorporated or used externally, in case of partial module shading, to maximize the output of module sections still illuminated.

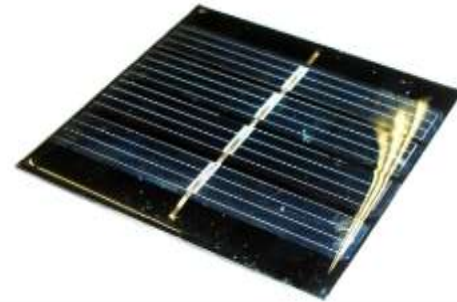

IV. BLOCK DIAGRAM:

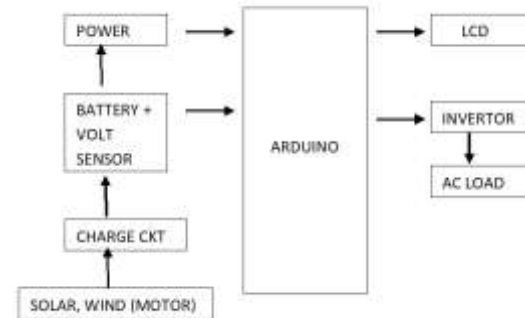

V. CONCLUSION

In this study, a novel architecture for a high frequency AC link inverter based on solar power was successfully constructed. One tiny inductor capacitor pair connected in parallel makes up the high-frequency AC-link. Due to their ability to operate at high frequency ac currents and voltages, both link components are light and tiny in size. In addition, link frequency is much higher than line frequency. This greatly reduces the significant losses and achieves the necessary efficiency. The simulation yields output values of 40V, 80V, and 150V, respectively, for input voltages of 50V, 100V, and 200V. For the same, a hardware experiment is carried out using a 12V input and an 11.5V output for the AC link inverter. Based on the study of the data, the inverter's ultimate efficiency is around 94%. Therefore, 90% of low power applications are best suited for the suggested inverter design.

REFERENCES:

- [1] Mahshid Amirabadi, Anand Balakrishnan, Hamid A. Toliyat and William C. Alexander, Member, IEEE “HighFrequency AC-Link PV Inverter” IEEE transactions on industrial electronics, vol. 61, no. 1, january 201
- [2] T. Kerekes, R. Teodorescu, P. Rodríguez, G. Vázquez, and E. Aldabas, “A new high-efficiency single-phase transformerless PV inverter topology,” IEEE Trans. Ind. Electron., vol. 58, no. 1, pp. 184–191, Jan. 2011.
- [3] M. Amirabadi, A. Balakrishnan, H. A. Toliyat, and W. Alexander, “Soft switched AC-link direct-connect photovoltaic inverter,” in Proc. IEEE Int. Conf. Sustain. Energy Technology, 2008, pp.
- [4] Aleksey Trubitsyn, Brandon J. Pierquet, Alexander K. Hayman, Garet E. Gamache, Charles R. Sullivan, David J. Perreault “High-Efficiency Inverter for Photovoltaic Applications”, 2010 IEEE Energy Conversion Congress and Exposition, pp. 2803-2810, Sept. 2010
- [5] Eftichios Koutroulisa, John Chatzakisa, Kostas Kalaitzakisa, Stefanos Maniasb, “System for inverter protection and real-time monitoring” Microelectronics Journal 34 (2003) 823
- [6] S. Chakraborty, B. Kramer, and B. Kroposki, “A review of power electronics interfaces for distributed energy systems towards achieving low-cost modular design,” Renew. Sustain. Energy Rev., vol. 13, no. 9, pp. 2323–2335, Dec. 2009.
- [7] H. A. Toliyat “Partial Resonant ac Link Converters” Journal of Electrical Systems and Signals, Vol. 1, No. 1, Mar. 2013
- [8] M. Amirabadi, H. A. Toliyat, and W. C. Alexander, “Battery-utility interface using soft switched AC link buck– boost converter,” in Proc. IEMDC, 2009, pp. 1299–1304.
- [9] G. Grandi, C. Rossi, D. Ostojic, and D. Casadei, “A new multilevel conversion structure for grid-connected PV applications,” IEEE Trans. Ind. Electron., vol. 56, no. 11, pp. 4416–4426, Nov. 2009.
- [10] Y. Huang, F. Z. Peng, J. Wang, and D. W. Yoo, “Survey of the power conditioning system for PV power generation,” in Proc. IEEE PESC, Jun. 18–22, 2006, pp. 1–6.
- [11] S. Atcitty, J. E. Granata, M. A. Quinta, and C. A. Tasca, “Utility-scale gridtied PV inverter reliability workshop summary report”, Sandia National Labs., Albuquerque, NM, USA, SANDIA Rep. SAND2011-4778
- [12] S. Jain and V. Agarwal, “An integrated hybrid power supply for distributed generation applications fed by nonconventional energy sources,” IEEE Tran. Energy Conversion. vol. 23, no. 2, pp. 622–631, Jun. 2008.